

VIP

-80°C Chest Freezer

84 L



MDF-C8V1-PE



PHCbi's MDF-C8V1 **VIP** -80°C Chest Freezer provides maximum sample storage capacity within an optimum footprint combined with industry leading cooling performance and reliability for an ideal long-term preservation solution.

Optimum Sample Storage

The use of patented VIP PLUS panels within the freezer cabinet provides a reduced wall thickness for maximum interior volume. This technology allows the MDF-C8V1 to require a small installation space with a great storage capacity.

Reliable PHCbi Technologies

A Cool Safe® compressor that is specifically designed for ultra-low temperature applications is employed in the proven PHCbi auto-cascade refrigeration system ensuring the highest levels of performance and reliability.

Ease of Use & Intelligent Security

Comprehensive setpoint, alarm, monitoring and diagnostic functions supervised by PHCbi-built microprocessor controller with digital display of all functions.

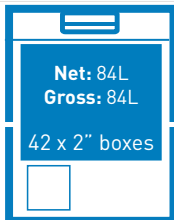
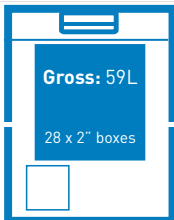

Personal Storage

Ideal for reliable storage of small volume clinical trial samples and temperature control testing.



Dependable Preservation

Quality of design and manufacture ensures trusted, reliable storage that maintains the integrity of precious samples.

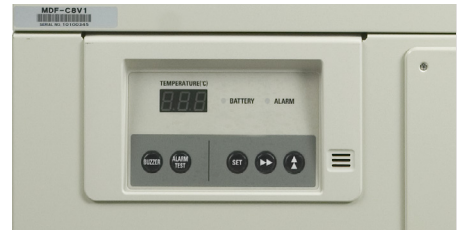

Uniform Sample Storage

The uniform and stable temperatures provided are ideal for storage of DNA, RNA and other important biological samples.

VIP -80°C Chest Freezer



Specially developed single-compressor system

The unique auto-cascade system uses a single compressor for efficient cooling, enabling an extremely small footprint. The highly efficient refrigeration system provides uniform and stable ultra-low temperatures with a reduced power consumption and extremely low noise operation.

Filterless Design

The unique cooling circuit makes the inconvenient customer maintenance procedure of filter cleaning unnecessary.

Minimal Footprint

PHCbi VIP ULT freezers provide up to 30% more storage capacity than a conventionally insulated freezer without increasing the footprint. The MDF-C8V1 features VIP PLUS vacuum panels for increased energy efficiency and cooling performance.

Microprocessor Control

Managed and monitored by an integrated microprocessor controller with a comprehensive alarm system and diagnostic functions.

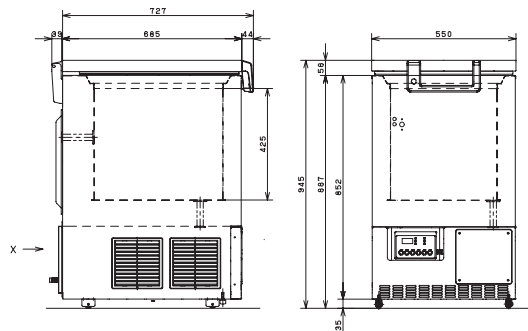

Model Number		MDF-C8V1-PE
External dimensions (W x D x H) ¹⁾	mm	550 x 685 x 945
Internal dimensions (W x D x H)	mm	405 x 490 x 425
Volume	litres	84
Net weight	kg	67
Capacity	2" boxes	42
Performance		
Cooling performance ²⁾	°C	-80
Temperature setting range	°C	-55 to -90
Temperature control range ²⁾	°C	-60 to -80
Control		
Controller		Microprocessor, non-volatile memory
Display		LED
Temperature sensor		Pt-1000
Refrigeration		
Compressor	W	400
Refrigerant*		MU-N49A
Refrigerant weight	g	315
Refrigerant GWP		4697
Total Refrigerant weight (CO ₂ equivalent)	t	1.480
Insulation material		PUF / VIP Plus
Insulation thickness	mm	70
Construction		
Exterior material		Painted Steel
Interior material		Stainless Steel
Outer Lid	qty	1
Outer Lid Lock		Y
Inner Lid	qty	1 (Styrofoam)
Access Port	qty	2
- position		Back/Bottom
- diameter	Ø mm	17
Casters	qty	4 [2 leveling feet]
Alarms [R = Remote Alarm, V = Visual Alarm, B = Buzzer Alarm]		
Power Failure		V-B-R
High Temperature		V-B-R
Low Temperature		V-B-R
Filter		Filterless design
Lid open		V-B
Electrical and Noise Level		
Power Supply	V	230
Frequency	Hz	50
Noise Level ³⁾	dB [A]	47
Options		
Liquid CO ₂ back-up ⁴⁾		MDF-UB4-PW
Temperature recorders		
- Circular type ⁵⁾		MTR-G85C-PE
- Chart paper		RP-G85-PW
- Ink pen		PG-R-PW
- Continuous strip type		MTR-85H-PW
- Chart paper		RP-85-PW
- Ink pen		DF-38FP-PW
- Recorder housing		MDF-S3085-PE

Appearance and specifications are subject to change without notice.

¹⁾ Exterior dimensions of main cabinet only, excluding handle and other external projections - See dimensions drawings on website for full details.

²⁾ Air temperature measured at freezer centre, ambient temperature +30°C, no load.

³⁾ Nominal value - Background noise 20dB[A].

⁴⁾ Requires mounting plate MDF-UBK-PW.

⁵⁾ Requires sensor cover MTR-C8-PW.

* Complies with Art. 11, Annex III of F-Gas Regulation (EU) No 517/2014. Contains fluorinated greenhouse gases.



PHC Europe B.V.

Nijverheidsweg 120 | 4879 AZ Etten-Leur | Netherlands

T: +31 (0) 76 543 3839 | F: +31 (0) 76 541 3732

www.phchd.com/eu/biomedical